

Manuscript received November 10, 2021; revised March 3, 2022; accepted May 21, 2022; date of publication May 30, 2022

Digital Object Identifier (DOI): <https://doi.org/10.35882/ijeemi.v4i2.6>

This work is an open-access article and licensed under a Creative Commons Attribution-ShareAlike 4.0 International License ([CC BY-SA 4.0](https://creativecommons.org/licenses/by-sa/4.0/))



Brake Current Control System Modeling Using Linear Quadratic Regulator (LQR) and Proportional integral derivative (PID)

Anggara Trisna Nugraha¹, Oktavinna Dwi Pratiwi¹, and Reza Fardiyan As'ad¹, Vijay Anant Athavale²

¹ Marine Electrical Engineering, Shipbuilding Institute of Polytechnic Surabaya, Surabaya 60111, INDONESIA

² Walchand Institute of Technology, Solapur, INDIA

Corresponding author: Anggara Trisna Nugraha (e-mail: anggaranugraha@ppns.ac.id).

ABSTRACT In the automotive world, each engine has different characteristics and functions, such as engine power, engine torque, and engine fuel emissions. Therefore, the power meter is used as a tool that can provide information about the engine characteristics. To ensure optimal braking performance of the dynamometer, eddy current braking dynamometer. This paper provides a comparative analysis between PID control as a classical control technique and modern control technique in the dynamometer eddy current brakes system. Eddy current brakes is a modern braking system that requires a control system to support the braking performance. PID control is often used to be implemented but, in some conditions, it is less optimal. This paper aims to find out that LQR and PID can support the performance of the Eddy current brakes dynamometer. And also to find out that LQR is better and optimal than PID controller for braking time response on Eddy current brakes dynamometer. Therefore, it is necessary to develop a modern and optimal control, such as a full state feedback Linear Quadratic Regulator (LQR). The expected result of the research is to produce a control design for the Eddy current brakes dynamometer system using the LQR control method. So that it can be used for the development of the automotive world and is beneficial for the survival of the community. The comparison of the braking time responses were simulated using Matlab/Simulink. The simulation results show that the response of LQR control is better than the PID, with $T_s = 2.12$ seconds, $T_r = 1.18$ seconds, and without overshoot. On the other side, PID control, although having $T_s = 0.27$ seconds and $T_r = 0.18$ seconds, there is still an overshoot about 0.7%.

INDEX TERMS: Eddy brakes, PID, LQR, Matlab

1. Introduction

The development of the automotive sector, especially in Indonesia, has experienced a very rapid increase over the last few decades, especially in the field of automotive engines. In the automotive world, each engine has different characteristics and functions, such as engine power, engine torque, and engine fuel emissions. Therefore, the power meter is used as a tool that can provide information about the engine characteristics. This tool is used to further analyze engine performance. In general, two types of experiments are carried out to determine the engine characteristics: constant braking test and maximum braking test [1]. An eddy current braking dynamometer is used to ensure optimal braking performance of the dynamometer.

The eddy current brakes dynamometer was chosen because it allows a high rate of load change, has good braking at high speeds, fast and stable conditions, and easy to control acceleration. It is ideal for testing motor performance by comparing an eddy current braking dynamometer with a highly flexible and inertial dynamometer [2]. In the eddy current brake dynamometer system, the current generated by changes in the magnetic flux on the conductive disc is

used as a trigger to generate braking force when testing the motor [3]. To get the optimal performance of the eddy current braking dynamometer, the parameters of time, the magnitude of the braking force, and the stability of the system during braking were analyzed.

To get the characteristics of the braking response time according to the standard, it is necessary to develop an optimal control system. The control method that is still widely used in industry is the classic PID controller. Some considerations for using this management method are simple and flexible design and implementation [4]. However, PID control is considered less than optimal in some situations for controlling applications such as eddy current braking dynamometers. Several studies related to the use of PID control generally lead to optimization of adjustment of control parameters [5]. However, it is also possible to create an optimal control system using controllers based on overall state feedback.

In some cases, controllers based on full state feedback are more sensitive than PID controllers. According to research conducted [6] using the integral state feedback control method to investigate the case control of DC motors. In this study, the implementation was tested using the Arduino embedded system. The

test results show that the controller based on full state feedback responds better than the PID controller because it takes a shorter time to reach the baseline. Another related study [7] was conducted to compare the performance of a PID controller and a Linear Quadratic Full Feedback (LQR) controller for DC motor position control. The performance of the LQR controller in this study is better, especially in terms of settling time and low overshoot criteria. PID and LQR were also compared in a tiltrotor controlling case study [8]. This study also gave positive results for the LQR controller, seen in the overshoot and response time criteria. Therefore, to improve the control design in a more modern direction, the use of an LQR regulator on the eddy current braking dynamometer system needs to be tested to achieve optimal response time when braking [16].

This paper aims to find out that LQR and PID can support the performance of the Eddy current brakes dynamometer. And also to find out that LQR is better and optimal than PID controller for braking time response on Eddy current brakes dynamometer. This research has a difference where, making a combination of using a method that is combined between Linear Quadratic Regulator (LQR) and Proportional integral derivative (PID). So, this paper discusses the control design simulation on the Eddy current brakes dynamometer system using the LQR control method. The simulation was built using Matlab software [17]. The Eddy current brakes system model used is in the form of state space. Observation of system response with and without controller using Simulink feature in Matlab. From the results of the response observations, then an analysis was carried out on the comparison of the results of the response between using PID classical control and LQR optimal control [18]. The expected result of the research is to produce a control design for the Eddy current brakes dynamometer system using the LQR control method. So that it can be used for the development of the automotive world and is beneficial for the survival of the community. The novelty of this research is the use of a combination of the Proportional integral derivative (PID) method as a method that will make the Brake Current get a fast response and the Linear Quadratic Regulator (LQR) is used to get the optimal value of the Brake Current system.

II. Materials and Method

A. Material

1) Eddy Current Brakes

The eddy current braking system with braking using electromechanical components can be said to be a more modern braking system compared to the mechanical braking system [9]. The braking system using an eddy current braking dynamometer provides a more responsive braking speed in high speed conditions, and has excellent durability because it does not contain mechanical parts that require special maintenance. Control [10]. The structure of the eddy current brake

model consists of a rotating conductive disk and a coil that is activated or permanently magnetized to create a magnetic field in the conductive disk [11]. By design, the eddy current brake is divided into four sections, as shown in FIGURE 1, with (1) a drive core and coil, (2) an airless gap, (3) a metal disc, and (4) an external information. side. of iron plate.

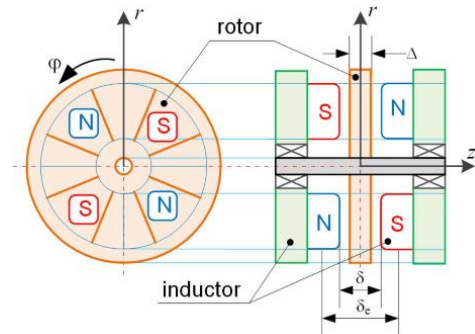

FIGURE 1. Schematic drawing of a permanent magnet eddy current disc brake. [12]

Description:

- a) Core and exciting coil
- b) Gap without air
- c) Iron plate
- d) The outer side of the iron plate

The performance system of the eddy current braking dynamometer is when the iron disc connected to the motor shaft rotates to receive the braking force input, the system uses a strain gauge sensor to determine the amount of braking force [19]. This sensor performs the function of detecting the magnitude of the braking force, which is converted into an analog signal and then the signal becomes a variable to be detected by the microcontroller. After receiving feedback from the load cell, the data is processed by the microcontroller to ensure a stable braking response of the system. Eddy currents are currents caused by changes in the magnetic flux in a conductor [1]. Here the conductor is an iron plate with a diameter of 10 cm which is attached to the engine shaft (dynamo). According to Lenz's law, eddy currents create a magnetic field in the opposite direction to the changing magnetic field that produces it. Therefore, the eddy current is used as the braking force of the dynamometer (F_b). This force F_b arises between the magnetic field vector and the eddy current.

At low speed conditions, the magnetic induction of the iron plate rotates and the eddy current becomes very small, so that the magnetic induction is almost perpendicular to the iron plate, so it can be neglected [20]. At medium speed conditions, the braking force is greater than before, so that induction occurs at the B0 pole so that the initial value of magnetic induction is ignored. The eddy current brake calculation diagram is shown in FIGURE 2, and several parameters are shown in TABLE 1. Based on the system simulation, the total braking force of the eddy current brake is formulated as equation (1).

$$F = \int_e^{g+e} dz \int_0^2 d\theta \int_{Rinner}^{Routter} \Delta F \theta r dr \quad (1)$$

TABLE 1

Eddy Current Brakes System Design Parameters [1]

Parameter	Value
Disc thickness (d)	1 cm
The angular velocity (ω)	3000 RPM
Disc and pole distance (x)	0.5 m

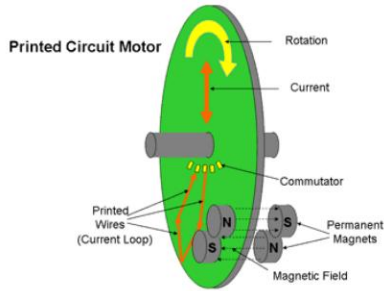

FIGURE 2. Eddy Current Brakes Dynamometer 3D Design [10]

Equations (2) and (3) are the result of solving the equation for the total braking force on Eddy current brakes. Where F is braking force (N), D is electromagnetic pole diameter (m), d is disk thickness (cm), B is magnetic induction (Tesla), c is proportional factor, ω is angular velocity (RPM), x is distance disk and pole (m) and R is disk radius (m).

$$F = 0.25 \frac{\pi}{4} D^2 d B^2 c \omega \tag{2}$$

$$c = 0.5 \left[1 - \frac{0.25}{\left(1 + \frac{\pi}{R}\right)^2 \left(\frac{R-x}{D}\right)^2} \right] \tag{3}$$

From all the specifications can be found the equation of the relationship between current (I) and braking force (F) as in Equation (4). Eddy current brakes dynamometer system modeling design which is represented in the form of state space and transfer function based on the derivation of Equation (2)-(3) to Equation (5) for state space and transfer function modeling in Equation (6).

$$I = 2.106 \ln (F) + 5.288 \tag{4}$$

$$x(t) = \begin{bmatrix} -2.029 & -2.826 \\ 4 & 0 \end{bmatrix} \begin{bmatrix} x_1 \\ x_2 \end{bmatrix} + \begin{bmatrix} 2 \\ 0 \end{bmatrix} u(t); y = [0 \quad 1.413]x(t) \tag{5}$$

$$G(s) = \frac{11.304}{s^2 + 2.209s + 11.304} \tag{6}$$

B. Method

This study uses a simulation system built using Matlab software. The Eddy current brakes system model used is in the form of state space [21]. Observation of system response with and without controller using Simulink feature in Matlab. From the results of the response observations, then an analysis was carried out on the comparison of the results of the response between using PID classical control and LQR optimal control [22].

Through modeling using state space and transfer functions, the response of the braking force system in an open loop can be analyzed to obtain the transient characteristics of the initial system response before designing the control design using PID or LQR [23]. The open loop model in the form of state space of the Eddy current brakes dynamometer system represented in the Simulink block is shown in FIGURE 3. The purpose of

the analysis of the two types of PID and LQR controllers is to compare the optimal system response to achieve the system response criteria.

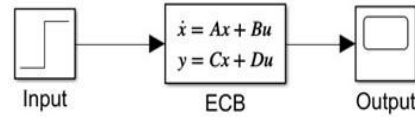

FIGURE 3. Simulink Block Eddy Current Brakes Open Loop Dynamometer System

C. Calculation Analysis

After obtaining the characteristics in the open loop condition, the PID and LQR control designs are carried out. The control design is carried out based on the application of literature review theory as the basis for designing the Eddy current brakes dynamometer control system in the Matlab/Simulink simulation, the following is the basic equation used for control design [24].

1) Proportional Integral Derivative (PID) Control

Integral Differential Proportional Control (PID) is a type of control commonly used in single-input, single-output (SISO) systems. The control system compares the error signal with the input signal (setpoint) using proportional, integral and derived parameters [13]. PID control is conventionally divided into two types, namely dependent on Equation (7) and independent on Equation (8). If expressed in terms of the transfer function in the s domain, it becomes in Equation (9)-(10). where u is the controller output, e is the error value, K_p is the proportional constant, K_i is the integral constant, and K_d is the derived constant.

$$u(t) = K_p \left[e(t) + \frac{1}{\tau_i} \int e(t) dt + \tau_d \frac{d}{dt} e(t) \right] \tag{7}$$

$$u(t) = \left[K_p e(t) + K_i \int e(t) dt + K_d \frac{d}{dt} e(t) \right] \tag{8}$$

$$u(s) = K_p \left[1 + \frac{1}{\tau_i s} + \tau_d s \right] e(s) \tag{9}$$

$$u(s) = \left[K_p + \frac{K_i}{s} + K_d s \right] e(s) \tag{10}$$

The search for constant parameters K_p , K_i and K_d for PID controllers is adapted from the Ackermann pole placement formula in Equation (12) with the characteristic equation in Equation (11).

$$|sI - A + BK_a| = (s - \mu_1)(s - \mu_2) \dots (s - \mu_n) = s^n + \alpha_1 s^{n-1} + \dots + \alpha_{n-1} + \alpha_n \tag{11}$$

$$K_a = [0 \quad 0 \quad \dots \quad 0 \quad 1] \begin{bmatrix} B \\ AB \\ \dots \\ A^{n-1}B \end{bmatrix} \theta(A) \tag{12}$$

Where $\phi(A)$ is $\phi(A) = A + \alpha_1 A + \dots + \alpha_{n-1} A + \alpha_n I$, and the gain value for full state feedback K_a in Equation (12) is as shown in Equation (13). With K^A to find the parameters K_p , K_i and K_d are as contained in Equation (14).

$$K_a = \begin{bmatrix} C & 0 \\ CA & CB \\ CA^2 & CAB \end{bmatrix} K \tag{13}$$

$$K = \begin{bmatrix} K_p \\ K_i \\ K_d \end{bmatrix} = (1 - K_a CB)^{-1} \begin{bmatrix} K_p \\ K_i \\ K_d \end{bmatrix} \tag{14}$$

FIGURE 4 shows a state space block diagram on Simulink for controlling the Eddy current brakes dynamometer system plant using PID control. So it's necessary to make an augmented system equation as in Equation (15).

$$x_a = A_a x_a + B_a u_a \tag{15}$$

$$A_a = \begin{pmatrix} A & B \\ 0 & 0 \end{pmatrix}, B_a = \begin{pmatrix} 0 \\ 1 \end{pmatrix}, u_a = K_a x_a, x_a = \begin{pmatrix} x \\ u \end{pmatrix}$$

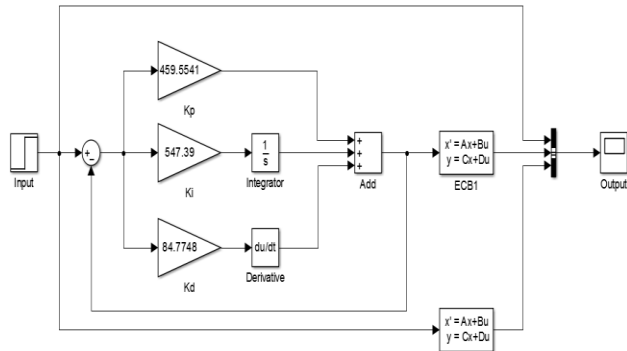

FIGURE 4. Simulink Block Eddy Current Brakes Dynamometer System with PID Control

2) Linear Quadratic Regulator (LQR) Control

Proportional Linear Quadratic Regulator (LQR) control is an optimization of a system with state space representation. LQR has the same structure as pole array with full state feedback, but the difference between LQR and pole array is how the K matrix is defined as feedback gain [14]. The control block diagram for a full-state feedback LQR system in a dynamometer system with eddy current brakes is shown in FIGURE 5.

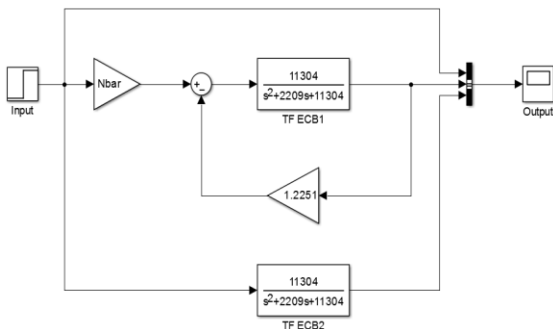

FIGURE 5. Simulink Block Eddy Current Brakes Dynamometer System with LQR Control

Pole placement control has the disadvantage of finding the gain matrix K used to move the system poles to the desired pole. These shortcomings are often overlooked in the systematic effort aspect. The result is high drive power consumption while trying to stabilize system response. With LQR control, this problem can be solved by using the gain matrix K obtained from the Q and R matrices of the LQR control system concept. The LQR control system has the ability to optimize the merit system figure and optimize the gain matrix K by considering the performance factors and system effort [15]. The optimal merit score is obtained by minimizing the value of the merit number in Equation (16).

$$J = \int_0^{\infty} (x^T Q x + u^T R u) dt \tag{16}$$

Through Equation (16) there is a symmetric real Q matrix which is definite positive (or semidefinite positive) and a symmetric real R matrix which is definite positive [25]. The Q matrix is used to adjust the performance of the system so that it is related to the system state vector, while the Q matrix affects the steady state error value in the system response, the greater the Q value, the smaller the steady state error value. The R matrix is used to modify each input state in the system to achieve the desired gain, this will affect the efficiency of the actuator's performance to stabilize the system. The R matrix will play a role in controlling each input state in the system in order to regulate the level of effort efficiency of an actuator. Through the performance index equation, the K gain value can be calculated using the equation as shown in Equation (17). Matrix P is the solution of the Riccati equation which is represented in Equation (18).

$$K = R^{-1} B^T P \tag{17}$$

$$A^T P + P A - P B R^{-1} B^T P + Q = 0 \tag{18}$$

However, the requirements that must be met before designing the control design using LQR are that the system must be controllable. That means the input signal u can control the dynamics of each state vector x. If the input signal u cannot control the dynamics of each state, it will result in setting the dynamics of the state using the Q matrix which cannot control the performance and the R matrix which cannot regulate the effort of the system. The controllability properties can be known by using the controllability matrix CM as shown in Equation (19). If rank n of the controllability matrix shows the same result as the order of the system, it can be said that the system is fully controllable.

$$C_M = [B \quad AB \quad A^2B \quad \dots \quad A^{n-1}B] \tag{19}$$

3) Zero Steady State Error Control Design

The overall feedback design of the LQR produces a transient response that meets the desired criteria, but undergoes a steady-state error response. The problem lies in the difference between the input and output responses of an infinite time system. The input response in question is called a closed loop system, that is, a reference or setpoint. The zero steady-state error analysis is carried out after the system is known to have reached stability. This analysis is used to correct the system error to reach a zero error condition, which means an error-free state under steady state conditions. There are several methods of zero steady state error analysis, namely using a non-feedback reference input gain using Nbar (N) and or using integral control (Ke). However, in the discussion of the design of the LQR Eddy current brakes dynamometer, this dynamometer uses a steady state error with a gain reference input of Nbar (N) which will produce a system response that is zero steady state error when a step signal is given. So that the control system design

structure can be described as in FIGURE 5 which is denoted by gain N. The gain value can be calculated by Equations (20) and (21), or by Equation (22) as the control signal equation. Then the gain of N in Equation (23) can be obtained.

$$\begin{bmatrix} N_x \\ N_u \end{bmatrix} = \begin{bmatrix} A & B \\ C & D \end{bmatrix}^{-1} \begin{bmatrix} 0 \\ 1 \end{bmatrix} \quad (20)$$

$$u = -Kx + (N_u + KN_x)r \quad (21)$$

$$u = -Kx - \bar{N}r \quad (22)$$

$$\bar{N} = N_u + KN_x \quad (23)$$

From all theoretical calculations starting from system modeling, designing the PID control design by determining the Kp, Ki and Kd parameters adapted from the Ackerman pole placement equation, then designing the LQR control by determining the Q matrix and R matrix to determine the full state feedback gain K and for achieving a zero steady state error condition using the gain reference input is done by computing in Matlab. The computational results are then simulated for each implementation of PID and LQR control on the Eddy current brakes system using Simulink.

III. Results

1) System Testing Without Controller

Testing the system without a controller is carried out by inputting the system as a 5 Newton (N) step signal, resulting in a brake time response as shown in FIGURE 6.

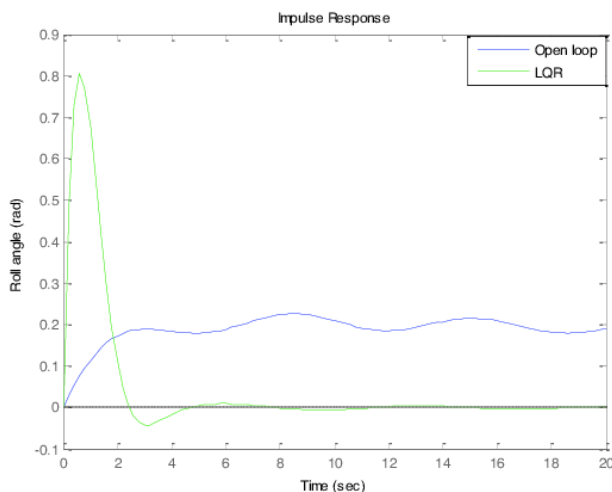

FIGURE 6. System Test Results Without Controller (Open Loop)

2) Eigen value and pole-zero map

Seeing the response of an open loop system that is still experiencing overshoot, eigenvalue search is used to see the steady-state value of the system modeled as state space. The results of the calculation of the eigenvalue system can be obtained using equation (24) with the results listed in equation (25).

$$\det(\lambda I - A) = 0 \quad (24)$$

$$\lambda = \begin{bmatrix} -1.0145 + 3.2054i & 0 \\ 0 & -1.0145 - 3.2054i \end{bmatrix} \quad (25)$$

3) PID Controller Test Results

The determination of the parameters Kp, Ki and Kd on the PID controller is set from the position of the

Ackermann poles with the first step determining the characteristic equation based on equation (12) the poles to be determined. PID control requires three parameters, whereas the system only has two, so an additional pole is required to expose the dominant pole placed on the far left. Thus, a final system with three poles is formed from the new reinforcement system as shown in equation (15). Then the value of Kp, Ki and Kd can be searched using the enhancement system.

The value of Ka gain for full state feedback is found by Equation (13), or by using the "acker" command in Matlab. After obtaining the value of Ka, it can be obtained the value of ^ from Equation (14), through the value of ^ the values of Kp, Ki and Kd are obtained. Through all these calculations, assuming the best pole location [-1 -5.2 -999] using Matlab calculations obtained the value of Kp = 459.5541, Ki = 547.3900 and Kd = 88.7448. After obtaining the PID parameter value, the system response is simulated using Simulink with a system model in the form of state space as shown in FIGURE 4 which produces an Eddy current brakes system response with 5 N braking force input using PID control as shown in FIGURE 7.

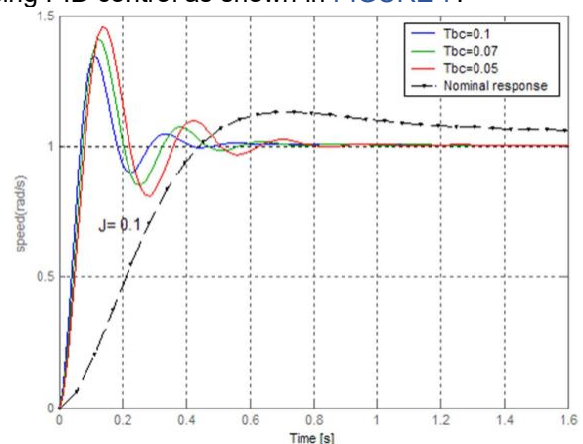

FIGURE 7. System Test Results with PID Controller

4) LQR Controller Test Results

Testing the response of Eddy current brakes using Simulink using an example in the form of state space, for example in Figure five, forming a response when braking, for example in FIGURE 8.

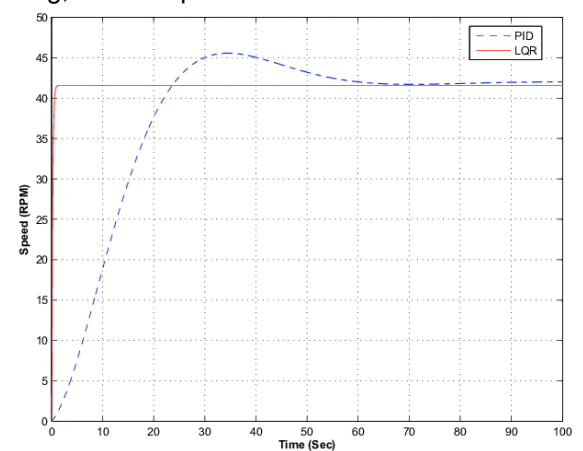

FIGURE 8. Results of the Second Test using the LQR Controller

In the second test, modifications were made to the values of the Q and R matrices as shown in Equation (26), which then obtained the gain value of $K = [2.7815 \ 0.0117]$. Furthermore, the gain value Nbar (N) is obtained at 1.0083

$$Q = \begin{bmatrix} 1 & 0 \\ 0 & 1 \end{bmatrix}, R = 1 \tag{26}$$

After modification, the response graph is obtained as shown in FIGURE 9. From the results of the second test using the LQR controller coupled with the gain reference input Nbar, it is able to provide a braking response time that matches the criteria.

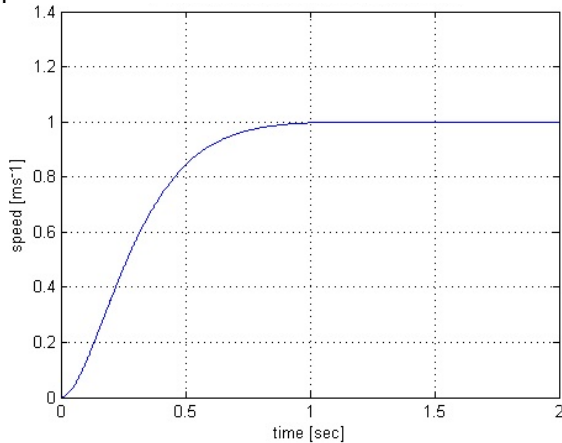

FIGURE 9. Results of the Second Test using the LQR Controller

5) Comparison of PID and LQR Control System Responses

TABLE 2 shows that using LQR control can make a better response when braking Eddy current brakes than using PID control, this is because using LQR control has a synchronous transient response output using the criteria of using a settling time (T_s) value of < 5 seconds & rise time (T_r) < 4 seconds which can still be said to be reasonable if implemented.

TABLE 2
Comparison of PID and LQR Controller Responses

Criteria	PID	LQR
Settling time	0.27 s	2.12 s
Rise time	0.18 s	1.18 s
% Overshoot	0.7	0
Steady state error	0	0
Fb (Braking Force)	5 N	5 N

IV. Discussion

1) System Testing Without Controller

The simulation results in FIGURE 6 show that the braking force value of 6.85 N exceeds the input value of 5 N which means it is overtaking and produces a transient system response with a stabilization time value of 3.34 seconds, a rise time of 0.394 seconds and an overshoot of 1.85 N or 36.9%. The stabilization and rise time values are good enough, but improvements are needed to bring the overshoot to the expected specs.

2) Eigen Value And Pole-Zero Map

When looking for the eigenvalues, it was found that the pole system was in the negative region (-1.0145-

3.2054i, -1.0145+3.2054i), which means the eddy current brake system is a stable system. However, in this system, a control design is needed so that the overshoot value in the system can be lowered according to the design criteria. The control design tested in this study used PID and LQR controls.

3) Pid Controller Test Results

Based on the system response in FIGURE 7, the settling time (T_s) value is around 0.27 seconds which is still classified according to the criteria, which is less than 5 seconds. However, this value is very unrealistic because the system response in real conditions is not possible with a time of less than 1 second. Likewise for the value of rise time (T_r) which is around 0.18 seconds. In addition, after being controlled using PID control, the overshoot value is still 0.7%. These results indicate that the use of the PID controller produces a system response that can achieve stability according to the criteria, although it has a significant gain increase with a gain of about 5.7 N in less than 1 second. Therefore, an experiment was carried out with the LQR controller as a comparison.

4) LQR Controller Test Results

In testing the system with the LQR controller, it begins by determining the diagonal matrix Q to adjust the system performance and the diagonal matrix R to adjust the system input which will be used to obtain the gain full state feedback matrix K based on Equation (17). With the help of Matlab these calculations can be done using the command "lqr()". However, before designing the LQR control, it is necessary to check the controllability of the system using the controllability matrix as shown in Equation (19). From this check, then the rank value for the controllability matrix is 2. This value indicates that all state variables in the Eddy current brakes system are fully controllable or can be controlled thoroughly because the rank value of the matrix is the same as the order of the system.

From the first test, the gain gain value is $K = [0.8025 \ 0.3181]$. The addition of the reference input gain calculated based on equations (20), (21), (22), and (23) obtained a gain value of 1.2251. After obtaining the reference input gain value to achieve zero steady state response, then the response test of the Eddy current brakes system with LQR control using Matlab is carried out and the results are shown in FIGURE 8. 2.19 seconds is good because it is still below the criteria limit of 5 seconds and is still in accordance with the conditions real. From the first experiment, it is necessary to improve the value of the Q and R Matrix to be able to increase the response to 5 N and improve the value of the overshoot percentage to 0%.

After modification, the response graph is obtained as shown in FIGURE 9. From this response, it can be seen that after repairing the Q and R Matrix and the input reference gain N as precompensation, it can be seen that the system response results can achieve stability with a braking force value of 5 N without any overshoot. The value of settling time (T_s) reaches 2.12

seconds which has met the criteria and the value of rise time (T_r) is 1.18 seconds which is also still in accordance with the predetermined criteria. The addition of N_{bar} is able to increase the system output gain, so that it matches the reference value and achieves a zero steady state error condition. From the results of the second test using the LQR controller coupled with the gain reference input N_{bar} , it is able to provide a braking time response that matches the criteria.

5) Comparison Of Pid And Lqr Control System Responses

From the results of the system response observations shown in TABLE 2, the use of LQR control can be said to be more optimal as a controller in the Eddy current brakes system because by using full state feedback LQR is able to regulate performance for the dynamics of each state vector system using the Q matrix and regulate the efficiency of actuator performance through The state vector input system uses an R matrix, so that it can produce a more optimal system response with a transient response that matches the criteria.

6) Data Analysis

The Eddy current brakes system using PID control produces a very fast transient response including the value of settling time (T_s) = 0.27 seconds and rise time (T_r) = 0.18 seconds, as well as an overshoot of 0.7% outside the system criteria. This response can be said to be less than optimal in the implementation of the Eddy current brakes system, because it requires a very high effort in controlling the braking force response with a very fast time so that it results in wasteful energy consumption to stabilize the braking force and if implemented on the hardware side it will not be optimal because braking response time is too fast. The weakness in controlling the system using PID control using K_p , K_i and K_d parameters is that it is not able to control every desired dynamics of the state variable on the Eddy current brakes system. In contrast to the full state feedback LQR control which can be said to be precise and optimal to be implemented in the Eddy current brakes system which is able to produce a response time that is in accordance with the criteria of settling time (T_s) = 2.12 seconds and rise time (T_r) = 0.18 seconds without any overshoot so that braking time is given a 2 second pause which can make the energy consumption of the controller to control Eddy current brakes more efficient. This is because the LQR control is able to regulate system performance and regulate the efficiency of actuator performance on system inputs, and full state feedback control has a method to eliminate steady state errors through additional gain reference inputs that can produce a more optimal system response with a transient response that matches the criteria. braking response time. So, the type of LQR control as a modern control can be an option for consideration in the development of the classical PID control method which is still often used in Eddy current brakes systems to

obtain more optimal braking force performance and energy efficiency in better braking force control.

Based on the data that has been obtained, the response of the LQR control system is better than the PID control. This is because the LQR control is able to regulate system performance and regulate the efficiency of actuator performance on system inputs. and LQR control can eliminate steady state errors so that the system response is more optimal with a transient response that is in accordance with the braking time response criteria. And then, the LQR control system can be applied to the eddy current brakes dynamometer system. With the use of the LQR control system, tools that use the dynamo system can become even more effective.

This study has a weakness that is it only compares 2 different methods. So it has limitations on the data obtained only on these 2 methods without testing other control system methods. Therefore, this research can be completed again by comparing other control system methods. So that we get an effective control system method for the eddy current brakes dynamometer system.

V. Conclusion

Based on the data that has been obtained, the Eddy current brakes system using PID control produces a very fast transient response including the value of settling time (T_s) = 0.27 seconds and rise time (T_r) = 0.18 seconds, as well as an overshoot of 0.7% outside the system criteria. And LQR Control is able to produce a response time in accordance with the criteria of settling time (T_s) = 2.12 seconds and rise time (T_r) = 0.18 seconds without any overshoot so that the braking time is given a 2 second pause which can make the controller energy consumption to control Eddy current brakes more efficient. LQR control is able to regulate system performance and regulate the efficiency of actuator performance on system inputs. And LQR control can eliminate steady state errors so that the system response is more optimal with a transient response that is in accordance with the braking time response criteria. Thus, the type of LQR control as a modern control can be an option for consideration in the development of the classical PID control method which is still often used in Eddy current brakes systems to obtain more optimal braking force performance and energy efficiency in better braking force control.

This study has a weakness that is it only compares 2 different methods. So it has limitations on the data obtained only on these 2 methods without testing other control system methods. Therefore, this research can be completed again by using several modern control methods to get the best control system results for the Eddy Current Brakes system.

References

- [1] Nahari, T., Joelianto, E., & Suyatman. (2012). An eddy brakes dynamometer control system design using state space based PID controller. 2012 IEEE Conference on Control, Systems & Industrial Informatics, (pp. 163–168).

- [2] Nunes, A. J. R., & Brojo, F. M. R. P. (2020, June 2). Designing an Eddy Current Brake for Engine Testing. *International Congress on Engineering - Engineering for Evolution*.
- [3] Cho, S., Liu, H.-C., Ahn, H., Lee, J., & Lee, H.-W. (2017). Eddy Current Brake With a Two- Layer Structure: Calculation and Characterization of Braking Performance. *IEEE Transactions on Magnetics*, 53(11), 1–5.
- [4] Munadi, M., Pandu, R. A., Wiradinata, R., Julianti, H. P., & Setiawan, R. (2020). Model and prototype of mobile incubator using PID controller based on Arduino Uno. *Jurnal*
- [5] Rao, C. S., Santosh, S., & V, D. R. (2020). Tuning optimal PID controllers for open loop unstable first order plus time delay systems by minimizing ITAE criterion. *IFAC- PapersOnLine*, 53(1), 123–128.
- [6] Ma'arif, A., & Setiawan, N. R. (2021). Control of DC Motor Using Integral State Feedback and Comparison with PID: Simulation and Arduino Implementation. *Journal of Robotics and Control (JRC)*, 2(5).
- [7] Handaya, D., & Fauziah, R. (2021). Proportional- Integral-Derivative and Linear Quadratic Regulator Control of Direct Current Motor Position using Multi-Turn Based on LabView. *Journal of Robotics and Control (JRC)*, 2(4).
- [8] Houari, A., Bachir, I., Mohame, D. K., & Mohamed, M. K. (2020). PID vs LQR controller for tilt rotor airplane. *International Journal of Electrical and Computer Engineering (IJECE)*, 10(6), 6309.
- [9] Gulbahce, M. O., Kocabas, D. A., & Atalay, A. K. (2013). A study to determine the act of excitation current on braking torque for a low power eddy current brake. *2013 International Electric Machines & Drives Conference*, (pp. 1321–1325).
- [10] Brin, W. (2013). Design and Fabrication of an Eddy Current Brake Dynamometer for Efficiency Determination of Electric Wheelchair Motors [Wright State University].
- [11] Chen, C., Xu, J., & Wu, X. (2019). Analytical Calculation of Braking Force of Super-High Speed Maglev Eddy Current Braking System. *2019 22nd International Conference on Electrical Machines and Systems (ICEMS)*, (pp. 1–5).
- [12] R. S. Robert, "2D model of axial-flux eddy current brakes with slotted conductive disk rotor," *2017 International Siberian Conference on Control and Communications (SIBCON)*, 2017, pp. 1-6, doi: 10.1109/SIBCON.2017.7998501
- [13] Isdaryani, F., Hesia, M. F. V., & Feriyonika, F. (2021). Sintesis Kendali PID Digital dengan Diskritisasi Langsung dan Backward Difference. *ELKOMIKA: Jurnal Teknik Energi Elektrik, Teknik Telekomunikasi, & Teknik Elektronika*, 9(2), 467.
- [14] Fahmizal, F., Arrofiq, M., Adrian, R., & Mayub, A. (2019). Robot Inverted Pendulum Beroda Dua (IPBD) dengan Kendali Linear Quadratic Regulator (LQR). *ELKOMIKA: Jurnal Teknik Energi Elektrik, Teknik Telekomunikasi, & Teknik Elektronika*, 7(2), 224.
- [15] Angga, Anggara Trisna Nugraha, Muhammad Jafar Shiddiq, and Moch Fadhil Ramadhan. "Use Ordinary Expressions to Learn How to Extract Code Feedback From the Software Program Upkeep Process." *International Journal of Advances in Data and Information Systems* 2.2 (2021): 105-113.
- [16] Purnawan, H., Mardijah, & Purwanto, E. B. (2017). Design of linear quadratic regulator (LQR) control system for flight stability of LSU-05. *Journal of Physics: Conference Series*, 890, 012056.
- [17] Angga, Anggara Trisna Nugraha, Muhammad Jafar Shiddiq, and Moch Fadhil Ramadhan. "Use Ordinary Expressions to Learn How to Extract Code Feedback From the Software Program Upkeep Process." *International Journal of Advances in Data and Information Systems* 2.2 (2021): 105-113.
- [18] Zakariz, Naufal Praska, Anggara Trisna Nugraha, and Khongdet Phasinam. "The Effect of Inlet Notch Variations in Pico-hydro Power Plants with Experimental Methods to Obtain Optimal Turbine Speed." *Journal of Electronics, Electromedical Engineering, and Medical Informatics* 4.1 (2022): 35-41.
- [19] Nugraha, Anggara Trisna, Moch Fadhil Ramadhan, and Muhammad Jafar Shiddiq. "DISTRIBUTED PANEL-BASED FIRE ALARM DESIGN." *JEEMECS (Journal of Electrical Engineering, Mechatronic and Computer Science)* 5.1 (2022).
- [20] Realdo, Adam Meredita, Anggara Trisna Nugraha, and Shubhrojit Misra. "Design and Development of Electricity Use Management System of Surabaya State Shipping Polytechnic Based on Decision Tree Algorithm." *Indonesian Journal of Electronics, Electromedical Engineering, and Medical Informatics* 3.4 (2021): 179-184.
- [21] Ruddianto, Ruddianto, et al. "The Experiment Practical Design of Marine Auxiliary Engine Monitoring and Control System." *Indonesian Journal of Electronics, Electromedical Engineering, and Medical Informatics* 3.4 (2021): 148-155.
- [22] Argentim, Lucas M., et al. "PID, LQR and LQR-PID on a quadcopter platform." *2013 International Conference on Informatics, Electronics and Vision (ICIEV)*. IEEE, 2013.
- [23] Olalla, Carlos, et al. "Robust LQR control for PWM converters: An LMI approach." *IEEE Transactions on industrial electronics* 56.7 (2009): 2548-2558.
- [24] Borrelli, Francesco, and Tamás Keviczky. "Distributed LQR design for identical dynamically decoupled systems." *IEEE Transactions on Automatic Control* 53.8 (2008): 1901-1912.
- [25] He, Jian-Bo, Qing-Guo Wang, and Tong-Heng Lee. "PI/PID controller tuning via LQR approach." *Chemical Engineering Science* 55.13 (2000): 2429-2439.