

Manuscript received August 03, 2022; revised September 01, 2022; accepted November 20, 2022; date of publication November 25, 2022

Digital Object Identifier (DOI): <https://doi.org/10.35882/ijeemi.v4i4.241>

Copyright © 2022 by the authors. This work is an open-access article and licensed under a Creative Commons Attribution-ShareAlike 4.0 International License ([CC BY-SA 4.0](https://creativecommons.org/licenses/by-sa/4.0/))

**How to cite:** Candra Prastyadi, Bambang Guruh Irianto, Her Gumiwang Ariswati, Dyah Titisari, Shubhrojit Misra, "Analysis of the Accuracy of Thermocouple Sensors at the Incubator Calibrator Laboratory Equipped with Internet of Thing-Based Data Storage", Indonesian Journal of Electronics, Electromedical Engineering, and Medical Informatics, vol. 4, no. 4, pp. 160–167, October. 2022.

# Analysis of the Accuracy of Thermocouple Sensors at the Incubator Calibrator Laboratory Equipped with Internet of Thing-Based Data Storage

Candra Prastyadi<sup>1</sup>, Bambang Guruh Irianto<sup>1</sup> , Her Gumiwang Ariswati<sup>1</sup>, Dyah Titisari<sup>1</sup>, Steyve Nyatte<sup>2</sup>  and Shubhrojit Misra<sup>2</sup> 

<sup>1</sup> Department of Electromedical Engineering Poltekkes Kemenkes, Surabaya, Jl. Pucang Jajar Timur No. 10, Surabaya, 60245, Indonesia

<sup>2</sup> University of Douala Cameroon, Cameroon

<sup>3</sup> Department of Electronics and Telecommunication Engineering, Jadavpur University, India

Corresponding author: Bambang Guruh Irianto ([bgi\\_dha@poltekkesdepkes-sby.ac.id](mailto:bgi_dha@poltekkesdepkes-sby.ac.id))

**ABSTRACT** Laboratory incubator is a tool used to incubate a breed. This incubator provides optimum temperature conditions for microorganisms to grow. It has a temperature regulator so that the temperature can be adjusted according to the breed incarnated. In this case, incubator worked like the hot-dry system of ovens. The purpose of this study was to conduct testing and analysis on the accuracy of thermocouple sensors using incubator media in laboratory incubator calibrator tools. The contribution of the research was to know the level of accuracy of the right sensor for sensing the temperature in the laboratory incubator. The main designed tool consisted of 8 MAX6675 standards, 8 K thermocouple, Arduino-Mega, and SD Card Standards. The temperature of the incubator device, in this case, was measured by the K thermocouple sensor. The sensor system had 8 channels that serve to measure the temperature at each incubator point. The temperature data were further stored in the SD card to analyze the data and the data can be processed into the form of a graphic. Benchmarking was done using a data logger temperature tool. This was done to make the designed tool results under the standards tool. After comparing between the tool designed and the standard tool obtained the largest error value of 3.98% in channel T6 at the temperature of 35°C with ordinary incubator media, while the smallest error in ordinary incubator media was at the point T6 at temperature of 37°C by 0.06%. Meanwhile, in the fan incubator, at the temperature of 35°C, had the largest error of 2.98%, while the smallest error was 0.86%. The conclusion of this study is that the tool designed could work well in measuring the temperature of the incubator, as well as the system for storing the data reading using the SD card which were sent using the internet network.

**INDEX TERMS** Laboratory incubator, Thermocouple, Calibration, IoT, SD card, MAX 6675.

## I. Introduction

A laboratory incubator is a tool used to incubate a breed [1]. Incubator provides optimum temperature conditions for microorganisms to grow [2]. This tool has a temperature regulator used to adjust the temperature according to the breed incarnated. In this case, incubator works like the hot-dry ovens [3][4][5]. In some types of incubators, humidity is provided by giving water to the incubator during the microbial growth [6][7]. This allows the environment to be wet thus slows down the dehydration of the medium, thereby avoiding biased environmental conditions [8][9]. Laboratory or bacteria incubator commonly sets the temperatures between 35°C and 37°C for testing the total coli group bacteria, which is a total group of aerobic, facultative anaerobic bacteria, gram negative, rod-shaped, does not form spores that can ferment

lactose by producing acid and gas at the temperature and time set [10][11][12][13]. The incubator uses a K-type thermocouple temperature sensor as a temperature reading [14]–[16].

Meanwhile, research has been done previously by Laura Valdes-Mora in validating the laboratory incubator using a wireless and thermocouple-based data logger. This study employed a measurement tool that has been calibrated and compared the data of measurement result from wireless and thermocouple data logger with 2 conditions of the incubator (filled condition and empty condition). In this case, the thermocouple used K-type thermocouple [17][18][19]. Furthermore, Dadan Saepul Rahman designed a vaccine refrigerator monitoring device using a microcontroller. In this research, the researcher set the temperature between 2°C and 8°C, linked it to the pc,

and found several disadvantages, including the non-wireless system [20]. Furthermore, another previous study was carried out by Rizkiyatussani where she designed a temperature calibrator tool with 5 (five) channels or 5 (five) temperature distribution points equipped with data storage on micro SD. In this case, the researcher used a K-type thermocouple sensor with temperature measuring points of 50°C, 100°C, and 150°C. The lack of analysis was concerning the temperature range which was only at 50°C, 100°C, and 150°C, while the temperature needed for the incubation process was 35°C and 37°C and the absence of wireless technology [21][22]. Aninda Zakia Febriyanti has also designed a temperature calibrator [23]. This tool used a K thermocouple sensor type and found the advantages of the use 5 (five) sensors and data storage using EEPROM. The lack of this study was the same as the previous study, which is the absence of wireless technology and the temperature examined was not the temperature needed for bacterial incubation which was 35 ° C and 37°C [24]. Furthermore, a simple and low cost humidity/temperature calibration system with data logger was designed by Yasser A. Abdelaziz, with temperature range of the designed calibration system started from 5°C to 98°C and from 50% rh to 98% rh for humidity. Again, the lack of this design is the absence of a wireless data transmission system [25]. In another research, Olivia Ratna Yunita also designed a temperature calibrator device with a thermocouple using an air medium and a stationer with a temperature of 30°C and 100°C. In this case, the advantages of the research found that this tool has displayed realtime graphics on the tool using plx-DAQ application. Meanwhile, the lack of this research was that the temperature media used was at 30°C, which was a room temperature and the use of wireless connections was still limited by distance [26]. Furthermore, Puspasari Fitri has researched temperature and humidity comparison tests using Arduino-based DHT22 sensor with thermohygrometer. The study reviewed the growing technological developments to facilitate temperature and humidity measurement using Arduino-based DHT22 sensors. Based on these results, it was concluded that the accuracy was considered good and acceptable because it was in accordance with the DHT22 sensor sheet data and the measured humidity was in the range of 2-5% and  $\pm$  °C 5 [19]. The analysis had the advantage of already using standard thermohygrometer as a comparison of temperature deficiencies measured at room temperature. In addition, this research has not used both temperature controlled media and has not analyzed thermocouple. Yunidar further also carried out relevant study in examining the performance of two temperature sensors for detecting the excess room temperature of this researcher. In this case, the researcher has used room temperature conditioning that was air conditioning. Meanwhile, the lack of this

research was that the research did not examined thermocouple sensor on controlled temperature media at a temperature of 35.37°C [27]. Yoga Alif Kurnia Utama in 2016 with his research further compared the skin of temperature sensors. The strength of this research was that the research has utilized four temperature sensors, including LM35, DHT11, DHT22, and DS18B20 sensors, while the weaknesses of this study was that it has not revealed thermocouple sensors in controlled temperature media [28][29][30]. This research used SD card as temperature reading data storage [31].

In this case, based on the discussion of previous studies, the authors have not found an analysis of sensor accuracy based on IoT systems and the monitored data which were stored in the SD card. Therefore, the purpose of this study was to test or analyze the accuracy of the k thermocouple temperature sensor by sending the data using the internet network in the manufacture of laboratory incubators to obtain more accurate sensor readings in the laboratory incubator room. This important research was conducted to assess the accuracy of the K Thermocouple sensor type so that the temperature read on the sensor is in accordance with the settings and needs of the incubator, so that the incubator will get maximum results.

## II. Materials and Methods

### A. Experimental Setup

In this study, the temperature sensor used was a K-type sensor utilized to sense the temperature in the laboratory incubator. Meanwhile, the data collection in this study was carried out at 8 sensor placement points in the laboratory incubator media with the temperature settings of 35°C and 37°C. In this case, each temperature measurement was carried out 6 times to determine the accuracy of the sensor readings. After that, the temperature setting measurement was further compared with the temperature reading on the Standard Thermometer with the manufacturer's thermometer. The purpose of this comparison was to determine the uncertainty and error of reading the K-Type sensor used in this study.

#### 1) Materials and Tool

In this study, the sensor used was a max6675 thermocouple type [32], utilized as a signal amplifier and a K thermocouple type, utilized for sensing the eight measurement points in a laboratory incubator [33]. Meanwhile, the microcontroller used was the Arduino Mega which was used to control the running of the system in this study [34]. For monitoring the temperature readings, the researchers created a data transmission system sent via the Internet of Thing using esp8266 [35] as data senders.

#### 2) Experiment

In this study, after the design was completed, the tests were carried out using a laboratory incubator media and compared with a data logger with 8 measurement

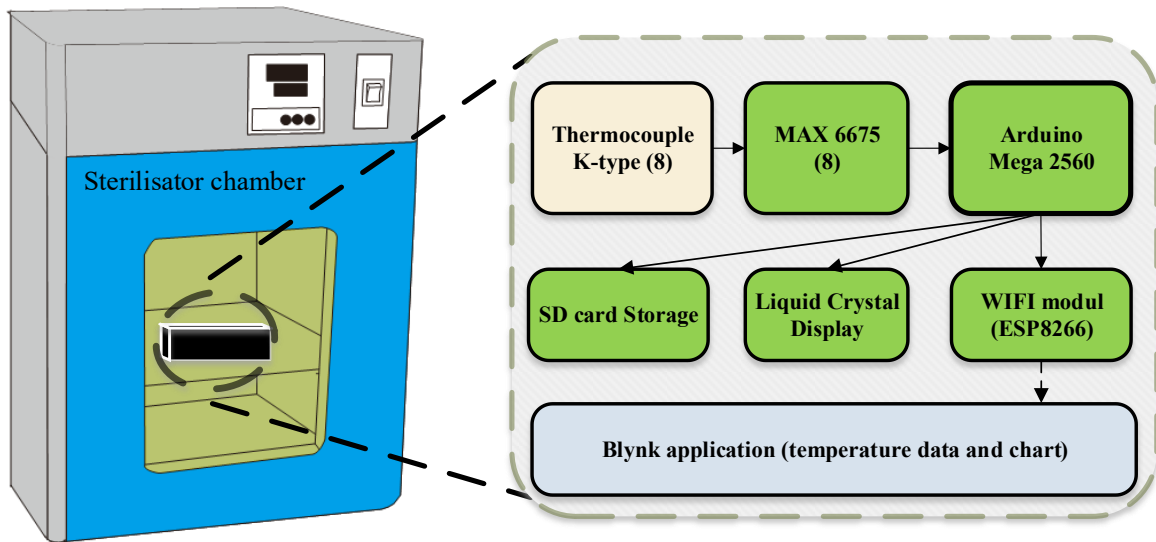

**FIGURE 1** Block diagram of the laboratory incubator system. The temperature sensor output is utilized as an analog signal conditioning input which will then be processed by the micro and later be an output for reading the temperature value displayed on the LCD and stored by the SD card.

points with temperature settings of 35°C and 37°C. In this case, each temperature setting was measured 6 times. The results of these temperature measurements were processed by the microcontroller and the data obtained were further sent and displayed in the android phone at each measurement point.

**B. The Diagram Block**

**FIGURE 1** shows the diagram of the system. The system starts working when the on button is pressed and the temperature sensor has been plugged into the device. The temperature sensor will further detect the temperature of the device then goes into the amplifier or signal the conditioning signal used so that the results of the sensor output that is very small (still analog) can be read. After the series of conditioning signal amplifiers, it was continued to the microcontroller for data processing and displayed them to the LCD. Furthermore, esp 8266 will send the data to the application or IoT provider to display the temperature sensor data in the form of decimal temperature and the results of the sensor reading can be stored with the storage of the IoT.

**C. The Flowchart**

**FIGURE 2** shows the flowchart of the system. When the tool is turned on, the tool initializes the temperature reading by the sensor and then it will be processed by the microcontroller for processing the temperature data reading. After that, the temperature data output is displayed by the TFT LCD. If the temperature is stable, then the start/stop storage button is pressed so that the data are stored by the sd card. In this case, the results of temperature storage on the sd card are managed using the Microsoft excel application. The reading data from the sensor is also sent using Wi-Fi Design and displayed in the Blynk sea application. To get an internet of things provider, In this case, the Blynk application can be downloaded on the play store and displayed in the Blynk sea application.

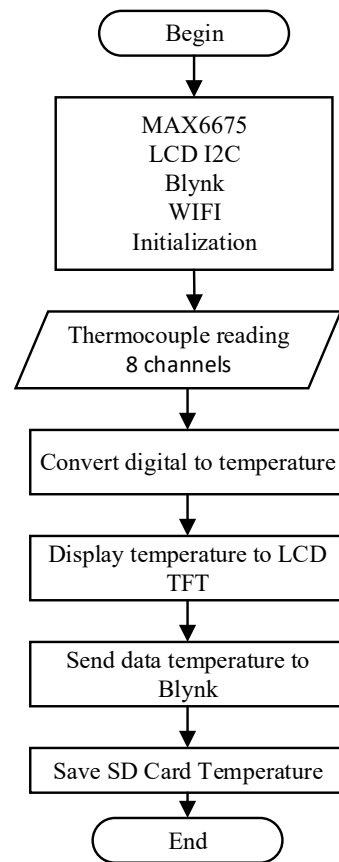

**FIGURE 1.** The flowchart: the temperature reading is then processed by Arduino which is then displayed on the LCD and stored in the SD Card.

**D. System circuit**

The important part of this development was the thermocouple and max6675 circuit described in Figure 3 (thermocouple circuit). This circuit was used for thermocouple sensors that read temperatures in Celsius. It will therefore be ready for digital processing using Arduino.

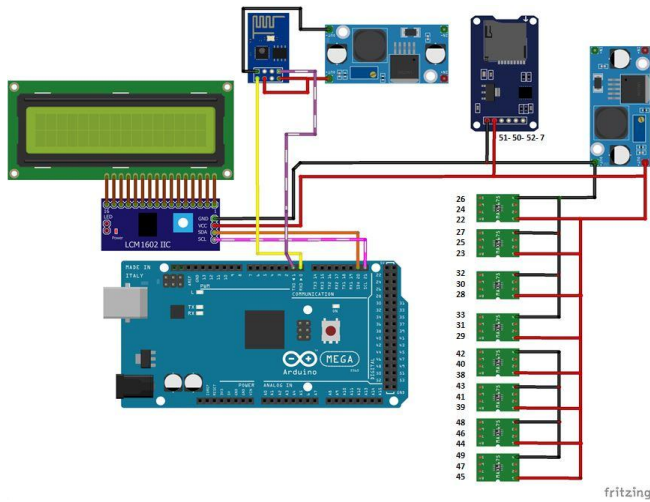

FIGURE 2. Thermocouple system circuit

III. Result

In this study, the Design has been tested on the temperature calibrator directly with the device using the UPTD datalogger tool. A minimum system was consisting of thermocouple sensor circuit, microcontroller, and thermocouple. In this study, it was the subsection of the Program to set the Celsius temperature readings of the thermocouple sensor at several points according to the coordinates on the character LCD. The program on Arduino was used to adjust the incubator temperature reading in Celsius units from the thermocouple sensor. In this case, the program used was "sensor1 = thermo1.read Celsius();" to read the temperature on the first thermocouple sensor and "sensor2 = thermo2.read Celsius();" This was the temperature reading on the second thermocouple sensor, and so on until the eighth thermocouple. Arduino programs were also used to store data. In this case, the program stored the data in the form of a txt file on the SD card. In addition to communicate with the SD card, the Arduino program was also used to connect IoT devices to the Blynk server. In this case, authentication was required to connect with Blynk. Security code was sent from the Blynk server to email via Project Settings on the AUTH TOKEN menu or characters in programming, as well as information about Wi-Fi networks used. The sensor value was in the form of float data that were sent to the Blynk server and displayed on the Blynk application that has been set into an android-based cellphone.

The following table shows the result of the errors comparison between the tool designed and standard device at the temperatures of 35°C, 37°C, and the temperature setting of 35°C, and 37°C in laboratory incubator. The measurement result of the data in the forms of average and standard value which were taken twenty-five times on the media incubator fan type and compared with the manufacturer's tool so that it obtained its accuracy level with a temperature setting of 37.0 °C at each sensor point of T1 to T8.

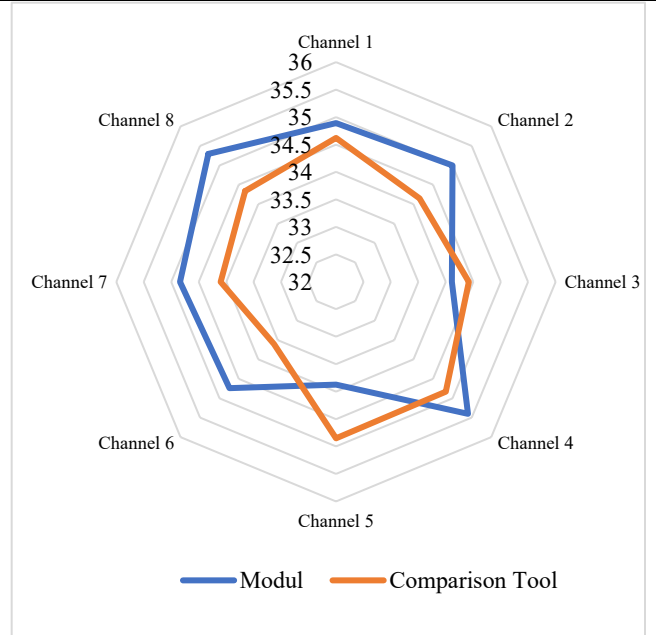

FIGURE 3. The comparison of the average results of the tool designed and the standard tool at the setting of 35°C

TABLE 1  
Standard error value against Standard

Channel	Setting (°C)	Average Design (°C)	Average Standard (°C)	Error (%)
1	35.0	34.89	34.62	0.78
2	35.0	35.00	34.15	2.49
3	35.0	34.11	34.42	-0.90
4	35.0	35.40	34.83	1.64
5	35.0	33.87	34.85	-2.81
6	35.0	34.74	33.60	3.39
7	35.0	34.84	34.10	2.17
8	35.0	35.29	34.34	2.77

TABLE 1 explains the calculation results of the average and standard values of 8 channels, where 8 temperature sensors placed at room points in a lab incubator with room temperature of 35°C. It can be seen that the readings on the tool designed had a difference with the highest error value was on channel 6 by 3.39% and the smallest error was in channel 3 with 0.9%. FIGURE 5 explained that the distribution of measurement points between channel 1 to channel 8 placed in a laboratory incubator with a temperature distribution at 35°C with blue color is a K thermocouple temperature sensor compared to standard equipment symbolized by orange with the average error value obtained was 3.39%

FIGURE 6 explains that the distribution of measurement points between channel 1 to channel 8 which were the measurement points placed in a laboratory incubator with a temperature distribution set at 37 °C symbolized with blue color, a K thermocouple temperature sensor, compared to standard equipment symbolized by orange with the average error value obtained was 2.26%. TABLE 2 explains that the calculation results of the average and standard values

of 8 channels placed at room points in a laboratory incubator set at room temperature of 37°C. It can be seen that the readings on the tool designed obtained a difference with the highest error value was on channel 2 with by 2.26%, while the smallest error value was on channel 3 by 0.06%.

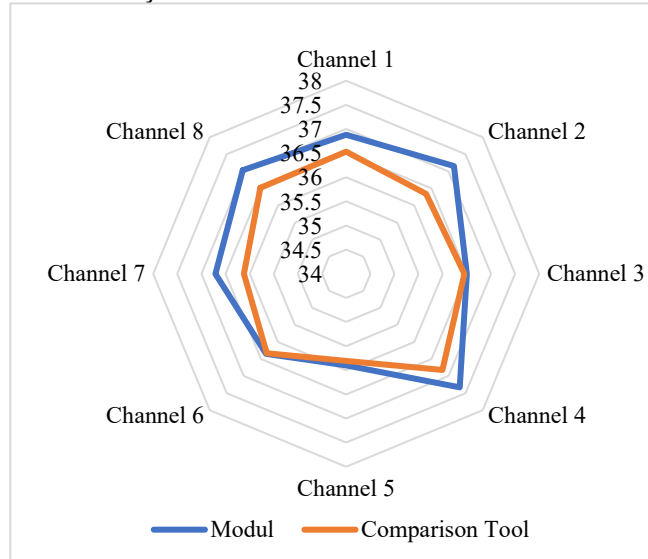

FIGURE 4. The comparison of the average results between the Designed tool and the Standard tool at the setting of 37°C

TABLE 2  
Standard error value against Standard  
Temperature 37°C Incubator

Chan nel	Setting (°C)	Average Design (°C)	Average Standard (°C)	SD Stand ar d	SD Standard	Error (%)
1	37.0	36.88	36.53	0.24	0.06	0.96
2	37.0	37.16	36.34	0.31	0.03	2.26
3	37.0	36.50	36.45	0.26	0.04	0.14
4	37.0	37.33	36.82	0.26	0.01	1.39
5	37.0	35.90	35.81	0.28	0.04	0.25
6	37.0	36.35	36.33	0.23	0.04	0.06
7	37.0	36.71	36.12	0.19	0.01	1.63
8	37.0	37.03	36.52	0.22	0.04	1.40

Furthermore, TABLE 3 explains the calculation results of the average and standard values of 8 channels which are 8 temperature sensors placed at room points in a lab incubator set at temperature of 37°C. It can be seen that the readings on the tool designed obtained a difference with the highest error value was on channel 3 by 2.50%, while the smallest error value was on channel 6 by 0.94%.

FIGURE 7 explains that the distribution of measurement points between channel 1 to channel 8 which were the measurement points placed in a fan laboratory incubator with a temperature distribution set at 37°C symbolized by blue color, a K thermocouple temperature sensor, compared to standard equipment symbolized by orange, with the average error value obtained was 2.50%.

TALBE 3  
Standard error value against Standard  
Temperature 37°C Fan Incubator

Chan nel	Setting (°C)	Average Design (°C)	Average Standard (°C)	SD Standa rd	SD Standard	Error (%)
1	37.0	37.05	36.68	0.28	0.06	1.00
2	37.0	37.02	36.45	0.23	0.03	1.56
3	37.0	37.57	36.65	0.31	0.04	2.50
4	37.0	36.95	36.51	0.23	0.01	1.22
5	37.0	37.03	36.54	0.29	0.04	1.35
6	37.0	37.11	36.77	0.18	0.04	0.94
7	37.0	37.20	36.39	0.29	0.01	2.23
8	37.0	37.38	36.75	0.22	0.04	1.70

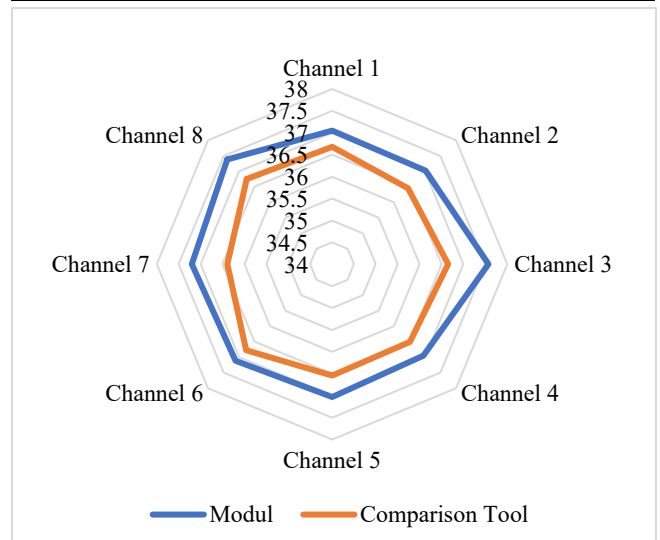

FIGURE 5. The comparison of the average results of Standard and the Standard (Standard) at setting 37°C

TABLE 4 explains the calculation results of the average and standard values of 8 channels which were 8 temperature sensors placed at room points in a lab incubator set at temperature of 35°C. It can be seen that the readings on the tool designed had a difference with the highest error value was on channel 3 by 2.98%, while the smallest was on channel 2 by 0.86%.

TABLE 4  
Design error values against Standards  
Temperature of 35°C of Fan Incubator

Chan nel	Setting (°C)	Average Design (°C)	Average Standard (°C)	SD Standard	SD Standard	Error (%)
1	35.0	35.08	34.52	0.25	0.02	1.61
2	35.0	35.06	34.76	0.34	0.05	0.86
3	35.0	35.65	34.62	0.22	0.02	2.98
4	35.0	35.35	34.70	0.29	0.02	1.88
5	35.0	35.36	34.51	0.21	0.01	2.45
6	35.0	35.17	34.75	0.25	0.00	1.21
7	35.0	35.39	34.59	0.23	0.01	2.31
8	35.0	35.19	34.62	0.29	0.02	1.65

FIGURE 8 explains that the distribution of measurement points between channel 1 to channel 8

which were the measurement points placed in a fan laboratory incubator with a temperature distribution set at 35°C symbolized with blue color, a K thermocouple temperature sensor, compared to standard tool symbolized by orange with the average error value obtained was 2.98%.

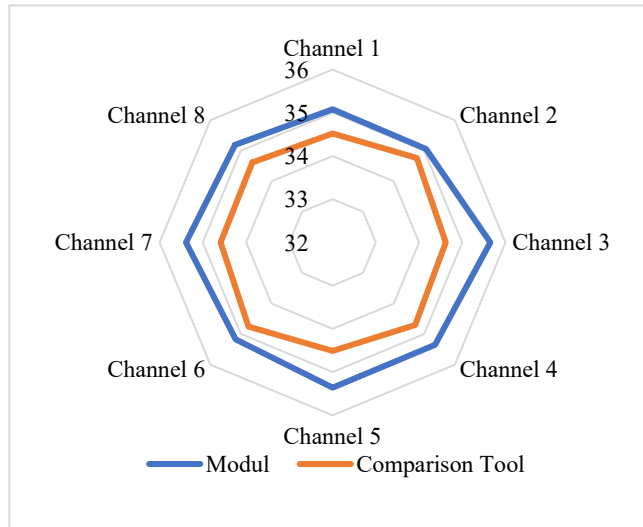

**FIGURE 6.** The comparison of the standard and average results between the tool designed and the standard tool at the setting of 35°C

#### IV. Discussion

The tool designed has been examined and tested completely and the sensor reading program for each channel on the tool designed can work properly. The K and MAX6675 thermocouple circuits worked well and the ESP Design could be connected to the predetermined network. The results of temperature readings in each thermocouple sensor (channel) were displayed on a 4x20 LCD which were further stored in the mini SD Card.

Based on the results of the data measured, it was seen that the results of temperature accession in incubator devices were close to the temperature compared. The results of temperature readings on each thermocouple sensor (channel) were displayed on a 4x20 LCD which were further stored on the mini SD Card.

Based on the data measurement, it can be seen that the result of adding temperature to the incubator was close to the temperature compared. In this case, the results of the measurement of designed tool using a multi-channel Standard obtained the largest error value of 3.98% on channel T6, at the temperature of 35 °C with ordinary incubator media, while the smallest error on the ordinary incubator media at T6 37°C was 0.06%. Meanwhile, the highest error of the fan incubator at 35°C was 2.98% and the smallest error was 0.86%, which was caused by several factors, one of which is the uneven temperature difference due to the distance between the heat source and different sensor placements. The measurement results from different incubators had various accuracy from each measurement point as well as fan and nonfan incubators which had different levels

of accuracy on the tool designed compared to standard tools. This research was a significant improvement from the previous study entitled Temperature Calibrator Using Microcontroller-Based Thermocouple [23], which did not use of wireless technology and the temperature chosen was not the temperature required for bacterial incubation of 35°C and 37°C. In practical systems, the incubator temperature calibration tool needs to use low temperatures for breeding utilization, as well as taking the advantage of the Internet of Things wireless connection to facilitate the temperatures on the media before data collection to improve efficiency.

Although there was an increase in this research, the error value between the tool designed and the standard design was still large because the data were displayed directly from the sensor reading output. In addition, the comparison sensor was a data logger type, so it had a weakness that the specifications were different from the thermocouple sensor. In addition, the use of tools was less efficient because the tools were not yet portable.

However, the weaknesses of this tool could be overcome by using a more accurate sensor or setting the sensor reading program. In addition, this tool could also use batteries so that the tool can be used as portable. This research was useful to develop tools using K Thermocouple sensors and also can make monitoring easier because it used an IoT system so that monitoring could be done on a cellphone. Furthermore, this tool was also provided with the data storage, so data on previous activities could still be accessed.

#### V. Conclusion

The purpose of this study is to analyze the accuracy of the thermocouple sensor using two types of incubators, those are a laboratory incubator temperature calibration tool at a temperature of 35°C and 37°C and a temperature sensor of a K thermocouple type with an Internet of Things connection and temperature data storage. This research shows that the comparison of data from two different incubator can determine the accuracy of the sensors in the incubator media. In summary, this study has been completely tested and obtained that the design can work properly as planned to measure the temperature of the incubator and store the readings in the SD card. In this case, the tool designed sends the data using the internet network. Further experimental research is needed by using other types of thermocouple sensors and thermocouple amplifier Standards so that the temperature readings are more accurate. In addition, a standard with similar sensors and making tools portable are also necessary in order to make it easier to use.

#### References

- [1] M. K. Zarkani, "Design and implementation of Laboratory incubator," Ministry of Higher Education & Scientific Research University of Kerbala, Republic of Iraq, 2020.

- [2] S. M. Lawal, M. Umar, and I. Muhammad, "Design and Performance Evaluation of an Automatic Temperature Control System in an Incubator," *Int. J. Appl. Electron. Phys. Robot.*, vol. 2, no. 1, pp. 8–12, 2017, doi: 10.7575/aiac.ijaep.v.2n.1p.8.
- [3] A. Chauhan and T. Jindal, "Equipments and Instruments for Microbiological Laboratories BT - Microbiological Methods for Environment, Food and Pharmaceutical Analysis," A. Chauhan and T. Jindal, Eds. Cham: Springer International Publishing, 2020, pp. 73–85.
- [4] A. Schertenleib, J. Sigrist, M. Friedrich, C. Ebi, F. Hammes, and S. Marks, "Construction of a Low-cost Mobile Incubator for Field and Laboratory Use," *J. Vis. Exp.*, Mar. 2019, doi: 10.3791/58443.
- [5] V. Thavaraj, B. Vashishth, O. S. Sastry, A. K. Kapil, and N. Kapoor, "Solar Powered Portable Culture Incubator," *Ann Pediatr Child Heal.*, vol. 3, no. 4, pp. 1–5, 2015.
- [6] D. Titisari and T. Kumar, "Nine Channels Temperature Data Logger Design for Dry Sterilizer Calibration," vol. 15, no. 2, pp. 88–95, 2022.
- [7] B. T. Heligman *et al.*, "The design and usage of a portable incubator for inexpensive in-field water analysis," *J. Humanit. Eng.*, vol. 6, no. 2, 2019, doi: 10.36479/jhe.v6i2.127.
- [8] U. Sarma and P. K. Boruah, "Design and development of a high precision thermocouple based smart industrial thermometer with on line linearisation and data logging feature," *Meas. J. Int. Meas. Confed.*, vol. 43, no. 10, pp. 1589–1594, 2010, doi: 10.1016/j.measurement.2010.09.003.
- [9] C. Bernardes, R. Bernardes, C. Zimmer, and C. C. Dorea, "A Simple Off-Grid Incubator for Microbiological Water Quality Analysis," *Water*, vol. 12, no. 1, 2020, doi: 10.3390/w12010240.
- [10] S. F. Hussin and Z. Saari, "Portable Incubator For E.coli and Coliform Bacterial Growth Using IoT," *Adv. Comput. Intell. Syst.*, vol. 2, no. 1, pp. 1–9, Nov. 2020.
- [11] C. Gutierrez, A. Somoskovi, K. Natarajan, and D. Bell, "Need for better adherence to optimal incubation temperature for quality laboratory diagnostics and antibiotic resistance monitoring," *Afr. J. Lab. Med.*, vol. 7, no. 2, pp. 1–2, 2018, doi: 10.4102/ajlm.v7i2.789.
- [12] E. Clasen, K. Land, and T. Joubert, "Micro-incubator for bacterial biosensing applications," in *Fourth Conference on Sensors, MEMS, and Electro-Optic System*, Feb. 2017, p. 100360G, doi: 10.1117/12.2245443.
- [13] J. Wight, M.-P. Varin, G. Robertson, Y. Huot, and A. Lang, "Microbiology in the Field: Construction and Validation of a Portable Incubator for Real-Time Quantification of Coliforms and Other Bacteria," *Front. Public Heal.*, vol. 8, p. 607997, Nov. 2020, doi: 10.3389/fpubh.2020.607997.
- [14] Y. Kusumawardani, E. Dian Setioningsih, and D. Titisari, "Water Bath Calibration Device with Data Storage Using Six Thermocouple Sensor," *J. Electron. Electromed. Eng. Med. Informatics*, vol. 2, no. 2, pp. 40–47, Jul. 2020, doi: 10.35882/jeeemi.v2i2.2.
- [15] S. N. Syayakti, E. D. Setioningsih, and S. Sumber, "4 Channel Sterilizer Calibrator," *Indones. J. Electron. Electromed. Eng. Med. Informatics*, vol. 1, no. 2, pp. 65–70, Feb. 2020, doi: 10.35882/jeeemi.v1i2.4.
- [16] M. Rofi'i, S. Syaifudin, D. Titisari, and B. Utomo, "Waterbath Calibrator with Nine Channels Sensor," *Indones. J. Electron. Electromed. Eng. Med. Informatics*, vol. 1, no. 1, pp. 1–6, Aug. 2019, doi: 10.35882/jeeemi.v1i1.1.
- [17] B. L. Valdes-mora and P. Hardt-english, "Validation of a Laboratory Incubator Using Wireless and Cabled Datalogger," *J. Valid. Technol.*, vol. 8, no. 2, pp. 162–173, 2017.
- [18] IEEE SA, "IEEE Standards Activities in the Internet of Things (IoT) Overview," no. November, pp. 1–4, 2018, [Online]. Available: <https://standards.ieee.org/initiatives/iot/stds.html>.
- [19] F. Puspasari, T. P. Satya, U. Y. Oktiawati, I. Fahrurrozi, and H. Prisyanti, "Accuracy Analysis of Arduino-based DHT22 sensor system against a Standard Thermohygrometer," *J. Phys. Appl.*, vol. 16, no. 1, p. 40, 2020, doi: 10.12962/j24604682.v16i1.5776.
- [20] D. Saepul Ramdan and M. Naufal Wijaksana, "Cold Storage Temperature Monitoring System Using Arduino-Based Data Logger and Visual Basic," *Sci. J. Informatics Manag. Comput.*, vol. 1, no. 3, pp. 107–112, 2017, doi: 10.32485/kopertip.v1i03.30.
- [21] Rizkiyatussani, Her Gumiwang Ariswati, and Syaifudin, "Five Channel Temperature Calibrator Using Thermocouple Sensors Equipped With Data Storage," *J. Electron. Electromed. Eng. Med. Informatics*, vol. 1, no. 1, pp. 1–5, 2019, doi: 10.35882/jeeemi.v1i1.1.
- [22] A. Nur *et al.*, "Development Of Application Programming Interface ( Api ) For Amikom Purwokerto Handsanitizer ( Ampuh ) Data Logger Pembangunan Application Programming Interface ( Api ) Untuk Visualisasi Data Logger Amikom Purwokerto Hand Sanitizer," *Jurnal Teknik Informatika*, vol. 3, no. 3, pp. 791–796, 2022.
- [23] A. Z. Febriyanti, P. C. Nugraha, and Syaifudin, "Temperature Calibrator Using Thermocouple Based on Microcontroller," *Indones. J. Electron. Electromed. Eng. Med. Informatics*, vol. 2, no. 1, pp. 13–20, 2020, doi: 10.35882/jeeemi.v2i1.3.
- [24] D. Singh, P. Kumar, and S. C. Prasad, "Calibration of thermocouples for low temperature applications," in *2016 International Conference on Recent Advances and Innovations in Engineering (ICRAIE)*, 2016, pp. 1–4, doi: 10.1109/ICRAIE.2016.7939485.
- [25] Y. A. Abdelaziz, "Low Cost Humidity / Temperature Calibration System," *J. Sci. Eng. Res.*, vol. 4, no. 10, pp. 305–311, 2017.
- [26] O. R. Yunita, D. Titisari, and T. Hamzah, "Temperature Calibrator with Thermocouple Equipped with Graphic Display," vol. 13, no. 1, pp. 32–42, 2020, doi: 10.35882/teknokas.v13i1.5.
- [27] Yunidar, Alfisyahrin, and Y. Rahmad, "Performance Analysis of NTC and LM35 Temperature Sensors in AVR ATmega 16 Microcontroller-Based Room Temperature Detection System," *J. Amplif.*, pp. 38–42, 2013.
- [28] Y. A. K. Utama, "Quality Comparison Between Temperature Sensors Using Arduino Pro Mini," *e-Jurnal Nar.*, vol. 2, no. 2, pp. 145–150, 2016.
- [29] A. Kus, Y. Isik, M. Cemal Cakir, S. Coşkun, and K. Özdemir, "Thermocouple and infrared sensor-based measurement of temperature distribution in metal cutting," *Sensors (Switzerland)*, vol. 15, no. 1, pp. 1274–1291, 2015, doi: 10.3390/s150101274.
- [30] E. Gavignet and F. Lanzetta, "Dynamic operation of a micro-thermocouple sensor as a vacuum gauge," *Vacuum*, vol. 100, pp. 18–21, 2014, doi: 10.1016/j.vacuum.2013.07.043.
- [31] Syarifatul Ainiyah, D. H. Andayani, A. Pundji, and M. Shaib, "Development of Incubator Analyzer Based on Computer with Temperature And Humidity Parameters," *J. Electron. Electromed. Eng. Med. Informatics*, vol. 2, no. 2, pp. 48–57, Jul. 2020, doi: 10.35882/jeeemi.v2i2.3.
- [32] S. P. Nalavade, A. D. Patange, C. L. Prabhune, S. S. Mulik, and M. S. Shewale, "Development of 12 Channel Temperature Acquisition System for Heat Exchanger Using MAX6675 and Arduino Interface," 2019, pp. 119–125.
- [33] H. H. Shaker, A. A. Saleh, A. H. Ali, and M. A. Elaziz, "Self-calibrating enabled low cost, two channel type K thermocouple interface for microcontrollers," in *2016 28th International Conference on Microelectronics (ICM)*, 2016, pp. 309–312, doi: 10.1109/ICM.2016.7847877.
- [34] S. Saha and A. Majumdar, "Data centre temperature monitoring with ESP8266 based Wireless Sensor Network and cloud based dashboard with real time alert system," in *2017 Devices for Integrated Circuit (DevIC)*, 2017, pp. 307–310, doi: 10.1109/DEVIC.2017.8073958.
- [35] W. G. Shun, W. M. W. Muda, W. H. W. Hassan, and A. Z. Annuar, "Wireless Sensor Network for Temperature and Humidity Monitoring Systems Based on NodeMCU ESP8266," 2020, pp. 262–273.